

B2/1, B3/1, B4/1, B../1

KHV-T Thermo

KZV-T Thermo

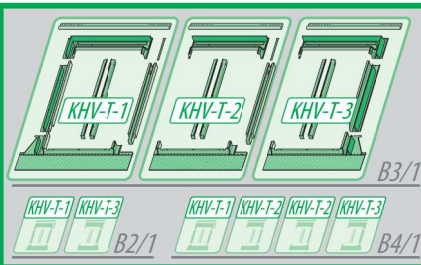
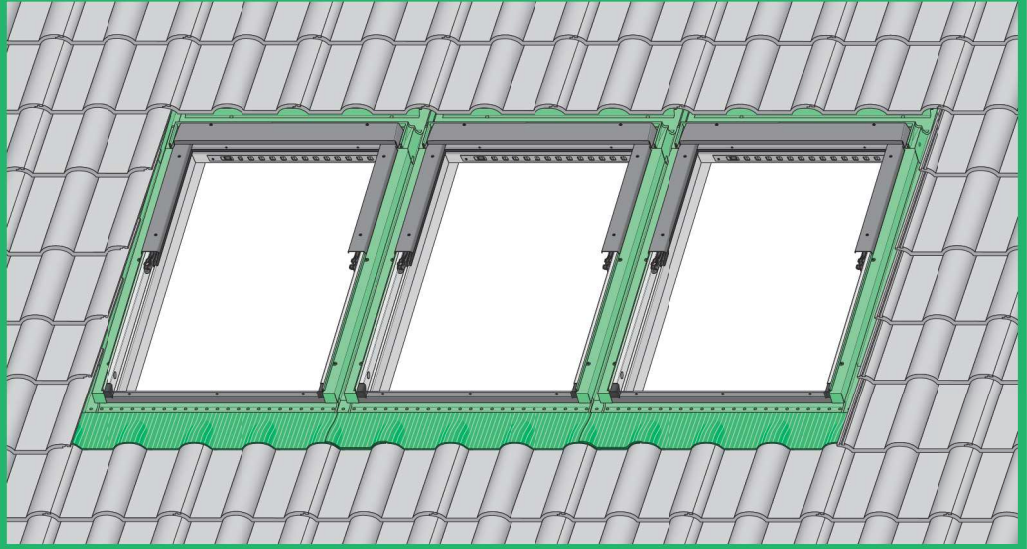

	-	-	-
		-	-
	KHV-T-1 + KHV-T-2 + KHV-T-3 Thermo Thermo Thermo		

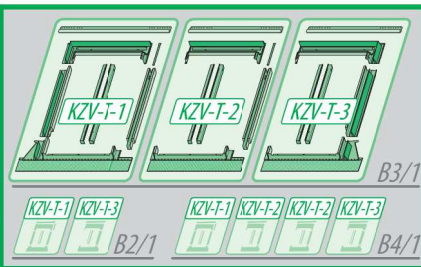

	-	-	-
		-	-
	KZV-T-1 + KZV-T-2 + KZV-T-3 Thermo Thermo Thermo		

B3/1 FTP-V KZV-T Thermo

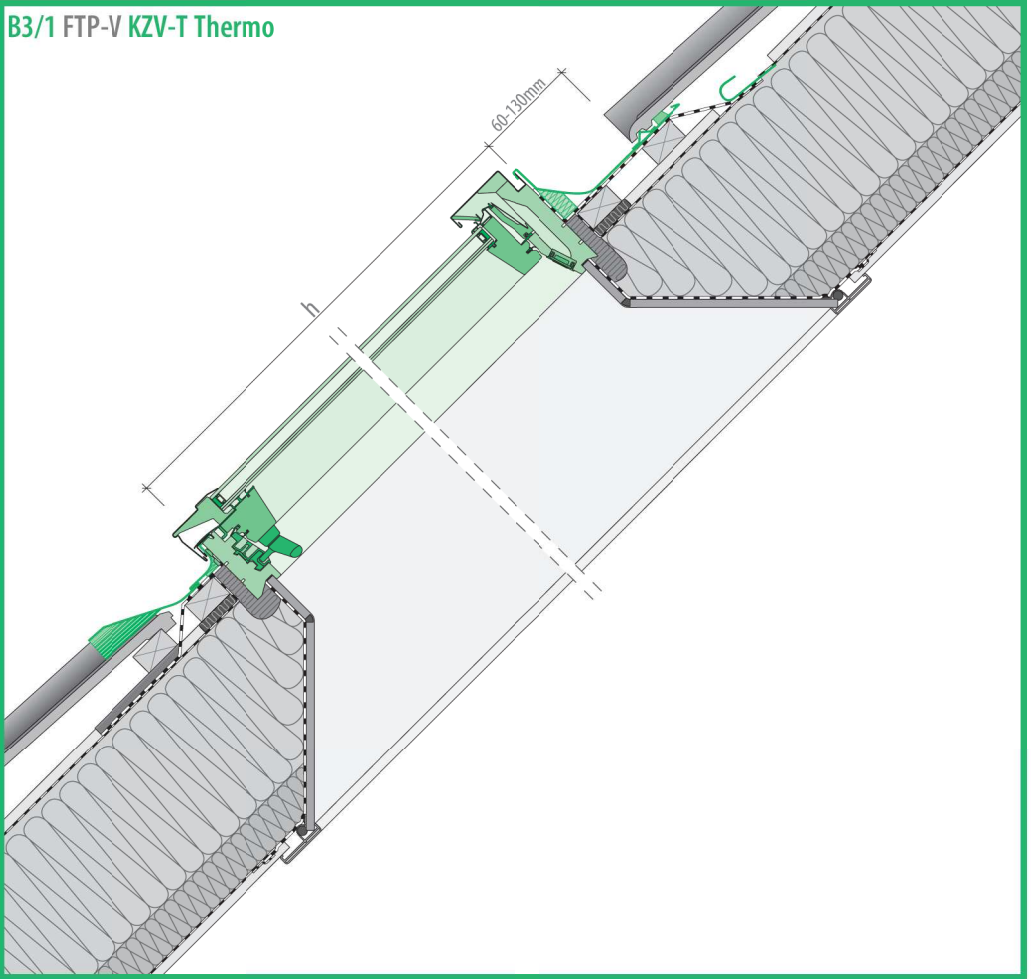

B3/1 FTP-V KZV-T Thermo

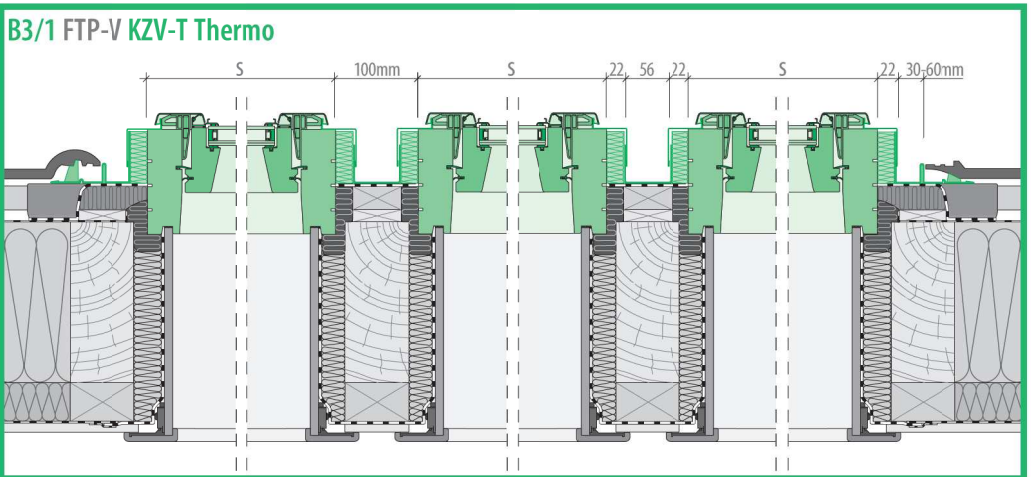

KHV-T Thermo KZV-T Thermo

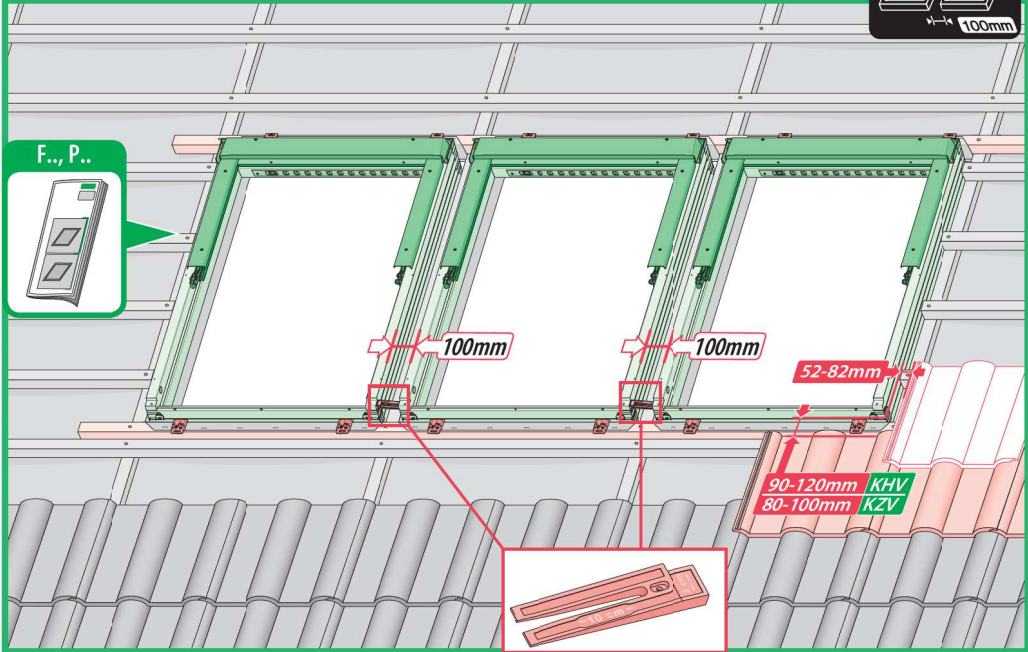

KHV-T Thermo KZV-T Thermo

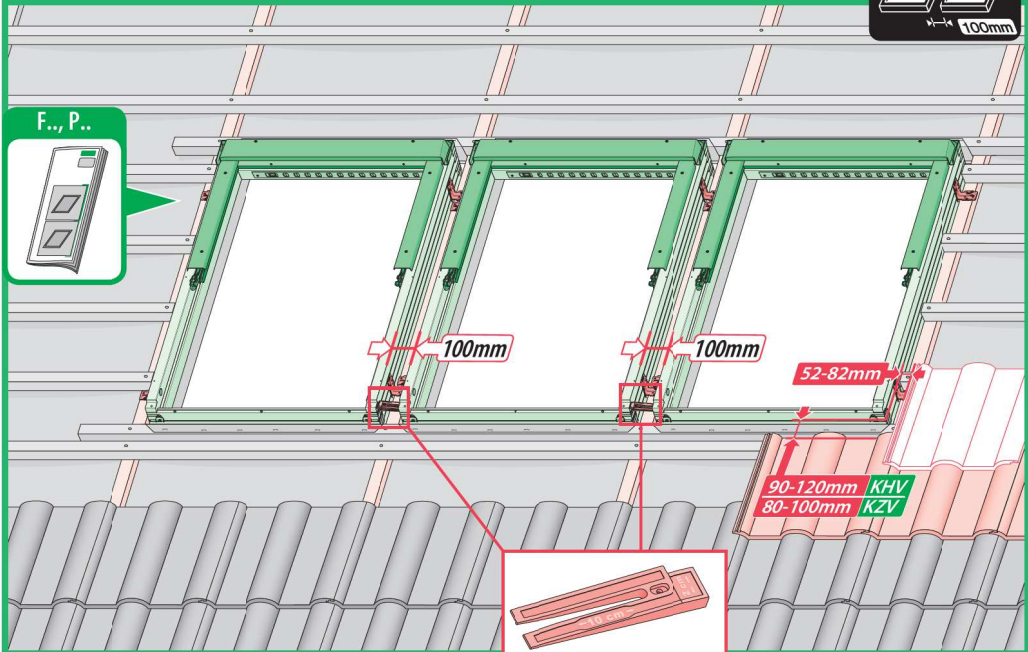
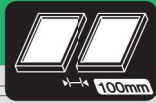

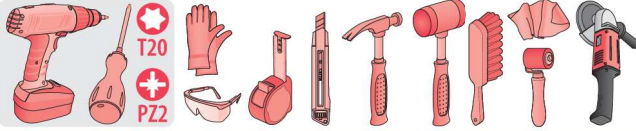

T20

PZ2

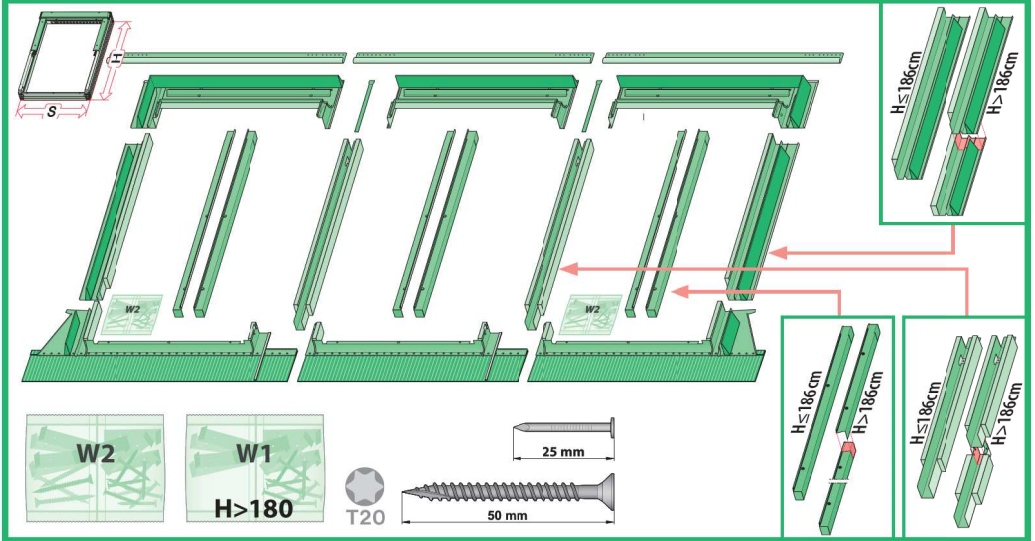

W2

W1

H > 180

T20

25 mm

50 mm

H <= 186 cm

H > 186 cm

H <= 186 cm

H > 186 cm

1a

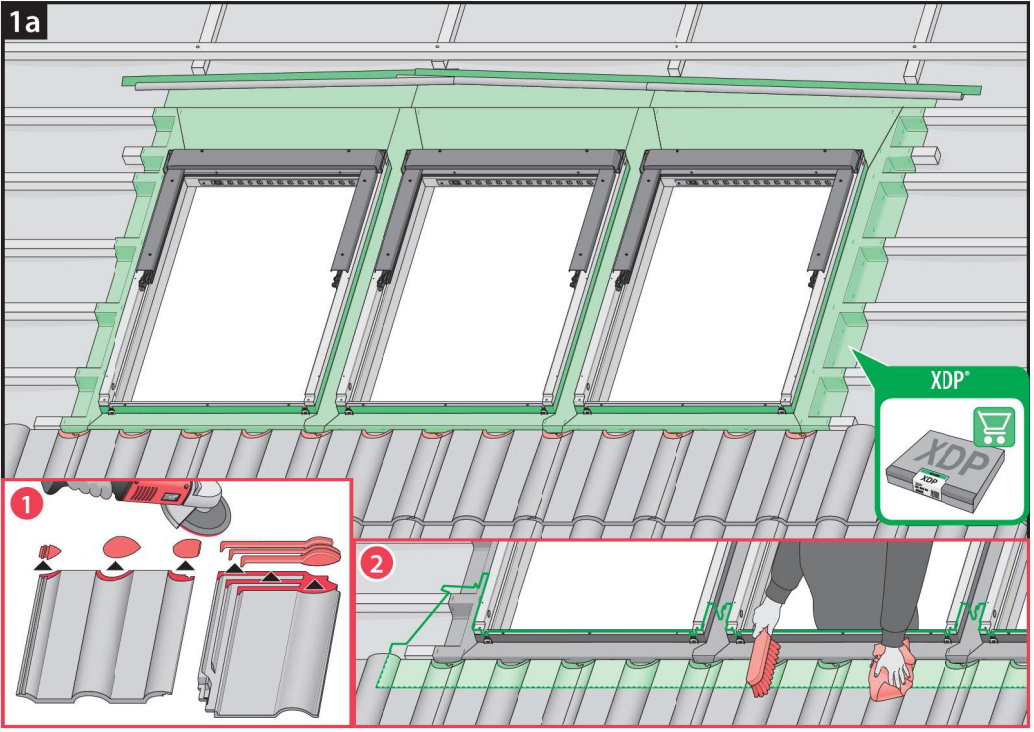

XDP®



1

2

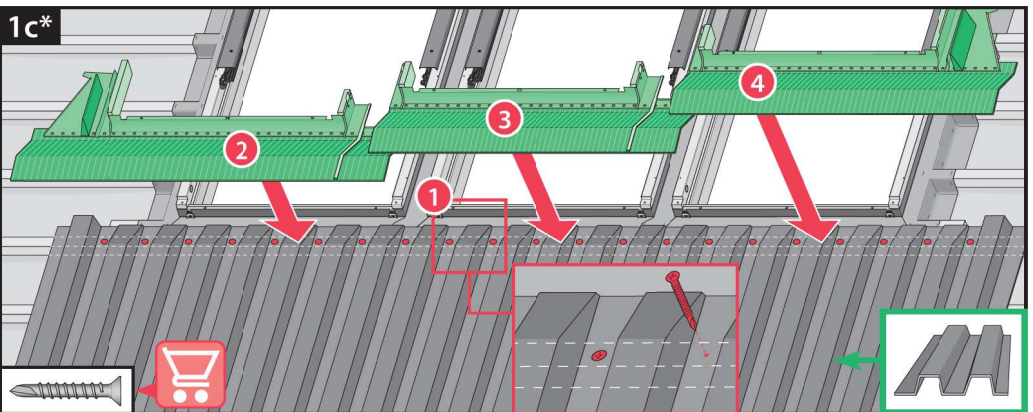
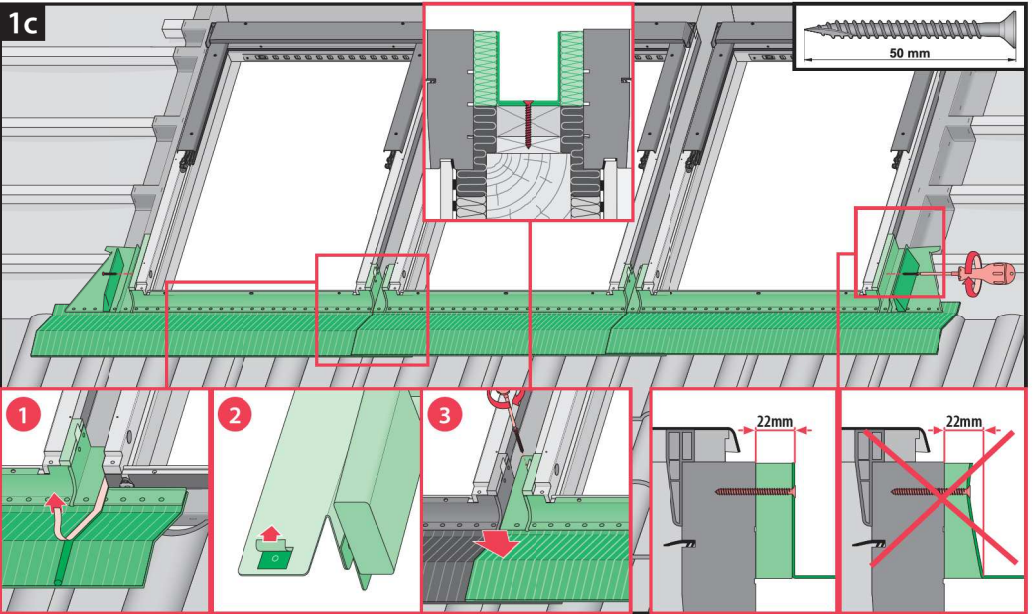
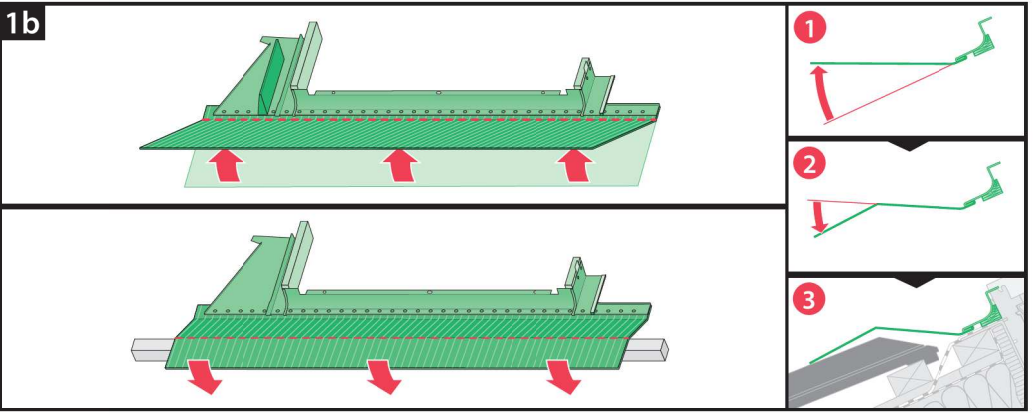

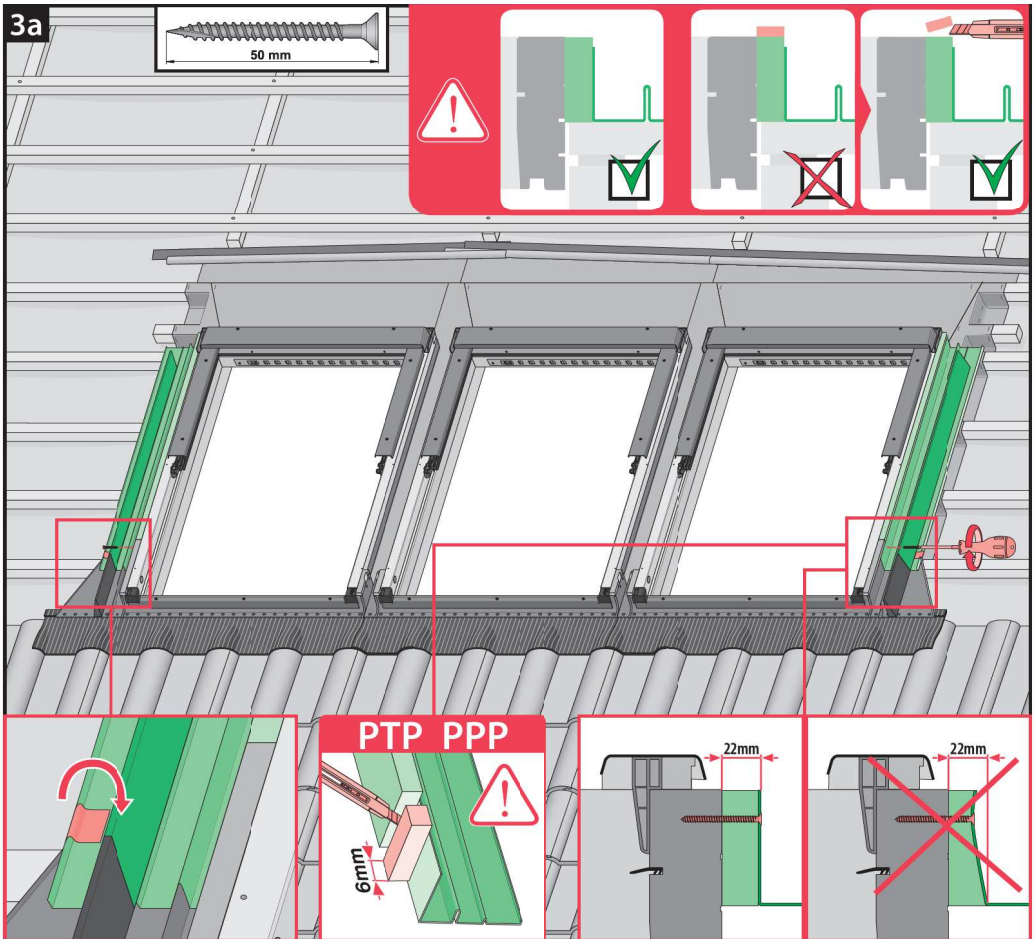
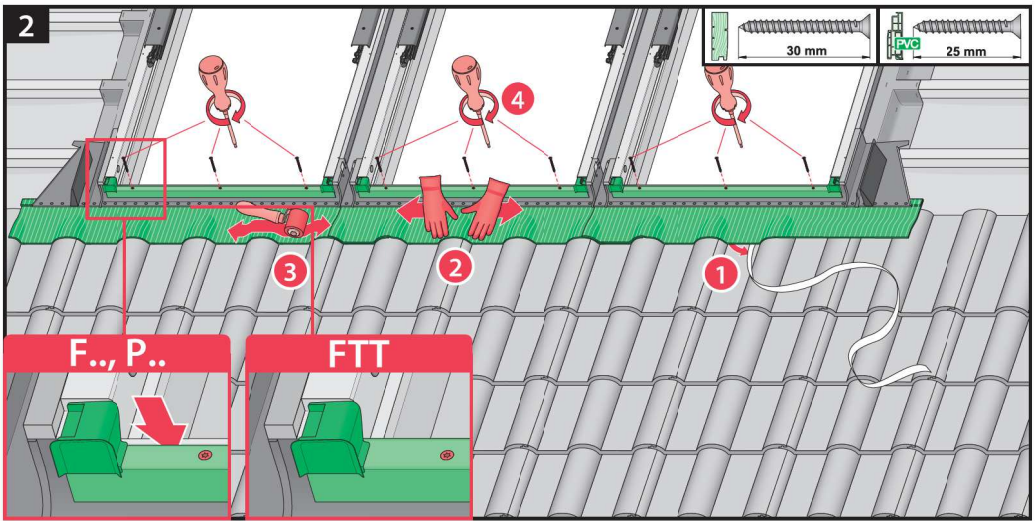

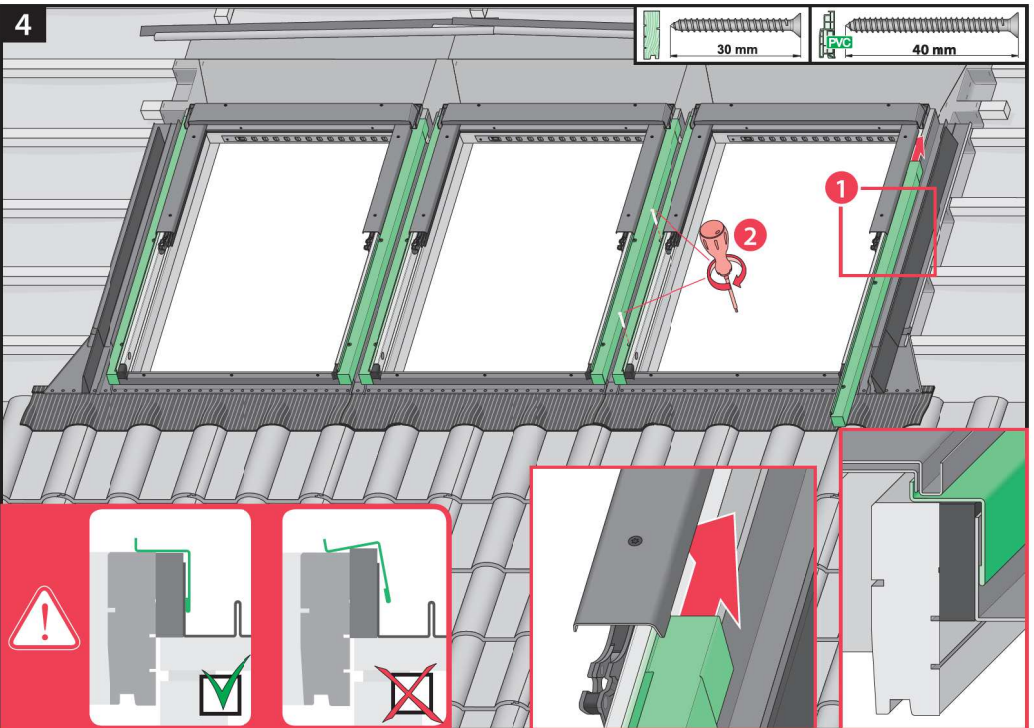
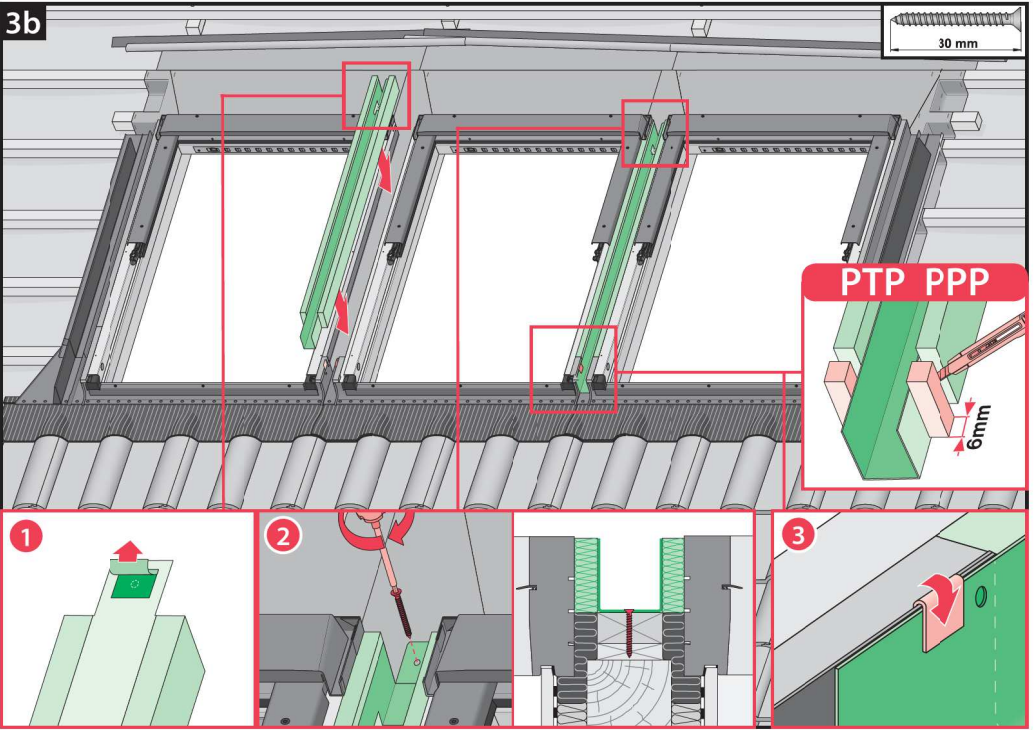

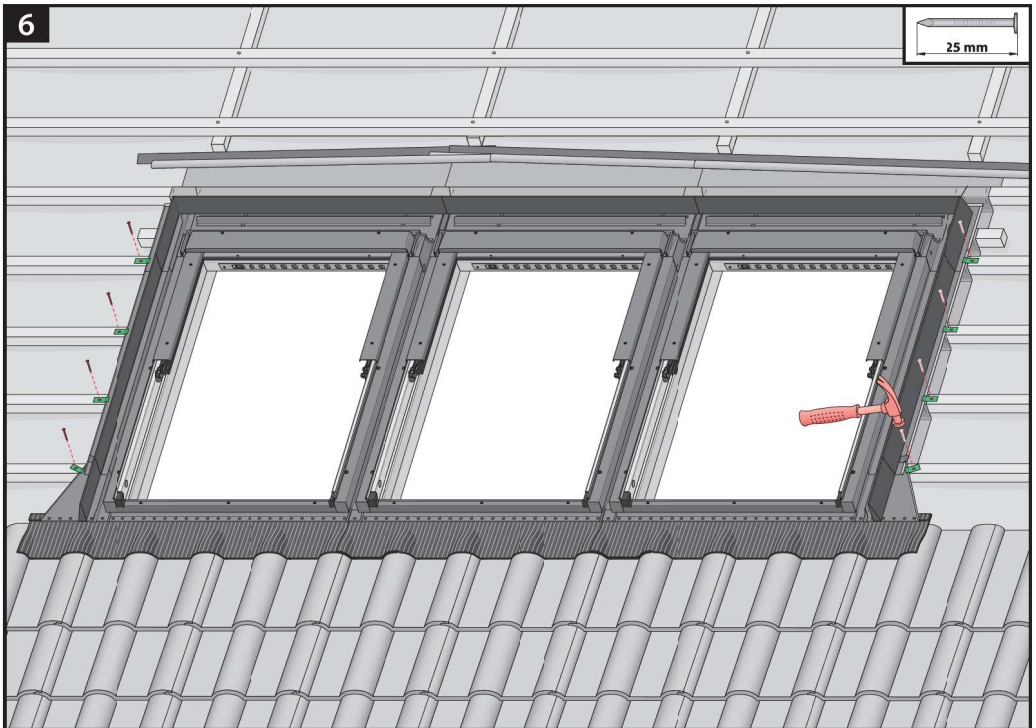
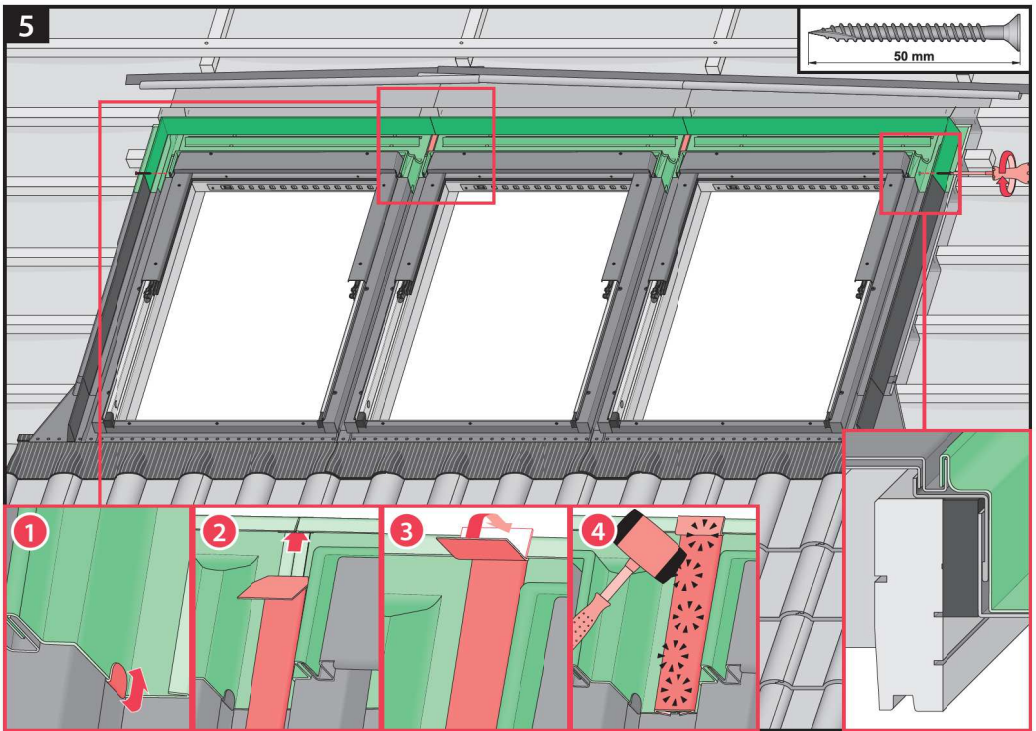

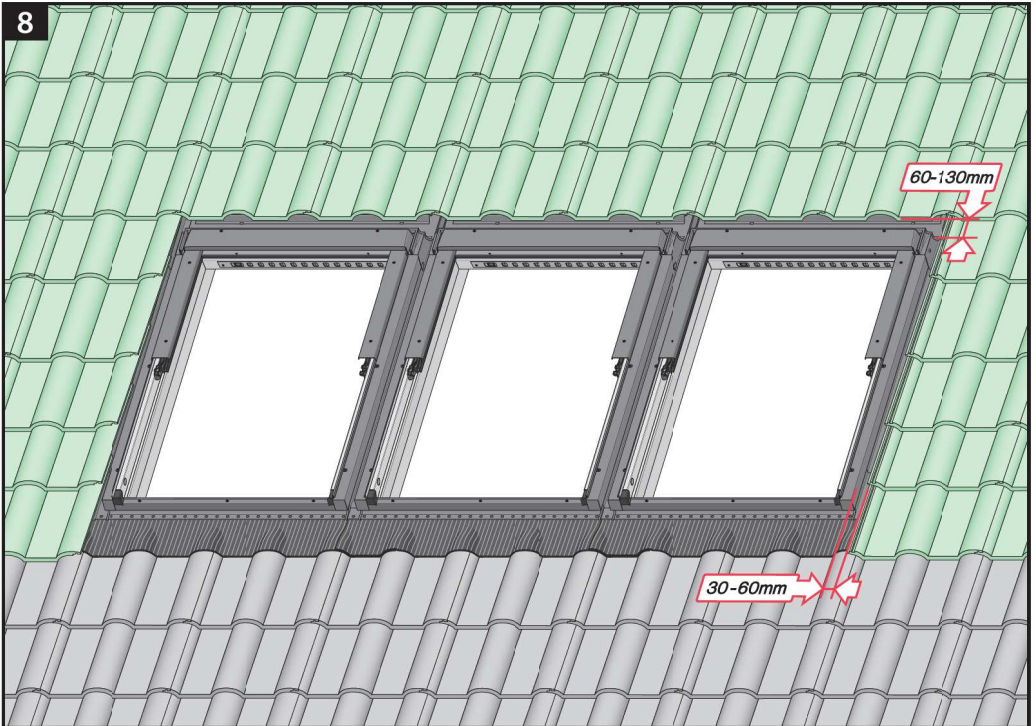
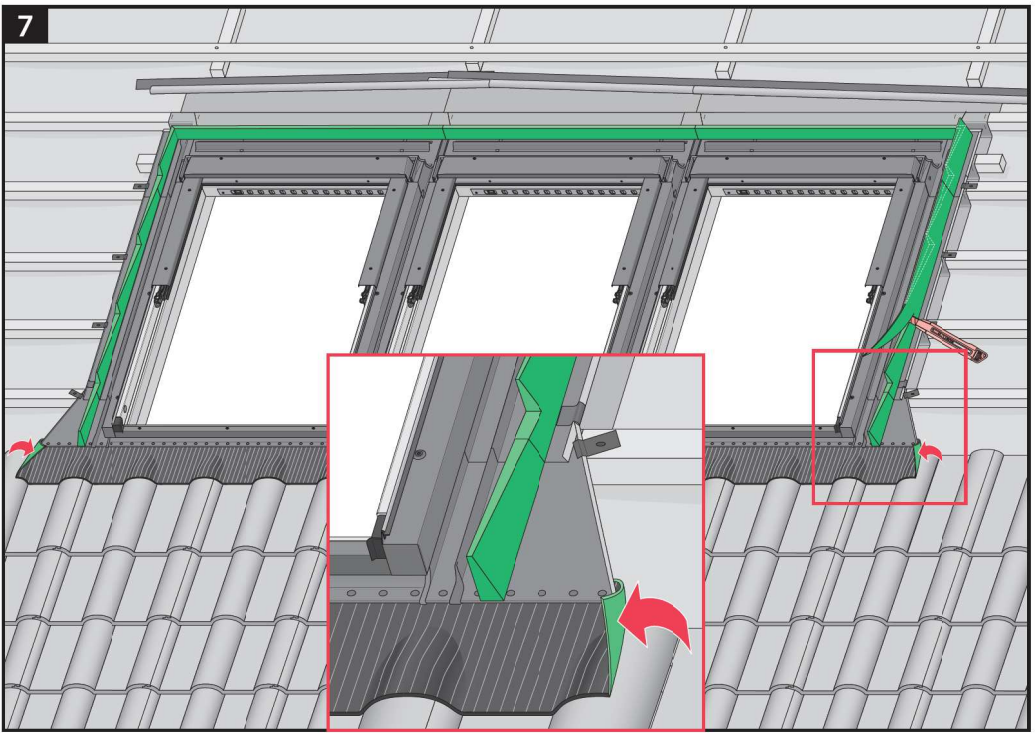

0 [cm] 1 2 3 4 5 6 7 8 9 10 11 12

BG	Производители / Продаван не носят отговорност за неспазване на съответните закони, строителни норми и изисквания за безопасност от потребителя на продукта, архитекта, монтажника или собственика на сградата.	IT	Il Produttore e il Rivenditore non potranno essere ritenuti responsabili per il mancato rispetto, da parte dell'utente del prodotto, del progettista, dell'installatore o del proprietario dell'edificio, delle leggi vigenti, nonché dei regolamenti edili e di quelli relativi alla sicurezza.
CZ	Utvůbce ani prodávce nemosí žádnou odpovědnost za nedodržení platných zákonů, stavebních předpisů a bezpečnostních požadavků uživatelem výrobku, architektem, montážníkem nebo vlastníkem budovy.	NL	De fabrikant en verkoper zijn niet aansprakelijk voor gevolgen bij het niet opvolgen van toepasselijke wetten, bouwbesluiten en veiligheidsvoorschriften door de gebruiker van het product, de architect, de installateur of de eigenaar van het gebouw.
DE	Hersteller und Verkäufer übernehmen keine Haftung für Nichtbeachtung entsprechender Rechts- und Bauvorschriften sowie Sicherheitsanforderungen seitens Produktbenutzers, Architekten, Monteure oder Gebäudebesitzer.	PL	Producent i Sprzedawca nie ponosi żadnej odpowiedzialności za nieprzestrzeganie stosownych przepisów prawa, przepisów budowlanych i wymogów bezpieczeństwa przez użytkownika produktu, architekta, montażystę lub właściciela budynku.
ES	El fabricante y el vendedor no tienen ninguna responsabilidad por el incumplimiento de la ley vigente, normas de construcción y exigencias de seguridad por parte del usuario del producto, arquitecto, instalador o el propietario del edificio.	PT	O fabricante e o vendedor não tem nenhuma responsabilidade pelo o não cumprimento da lei, códigos de construção e as exigências de segurança por parte do usuário do produto, arquiteto, instalador ou proprietário do edifício.
FR	Le fabricant et le vendeur ne prend aucune responsabilité de ne pas respecter les lois applicables, les règlements sur les bâtiments et les exigences de sécurité par l'utilisateur du produit, l'architecte, l'installateur ou le propriétaire du bâtiment.	RO	Nici producătorul, nici distribuitorul nu își vor asuma niciun fel de răspundere pentru nerespectarea legilor în vigoare a legilor din domeniul construcțiilor sau a măsurilor de siguranță impuse utilizatorilor produsului, arhitecților, montajorilor sau proprietarilor clădirii.
GB	Manufacturer and Sellers shall bear no liability for failure to comply with the applicable laws, building codes and safety requirements by the user of the product, architect, fitter or owner of the building.	RU	В случае несоблюдения архитектором, монтажником или владельцем здания строительных правил и норм безопасности ответственность с производителя и продавца снимается.
HU	A gyártó és a forgalmazó nem vállal semmilyen felelősséget a vonatkozó törvények, építési és biztonsági előírások, stb. nem tartásáért.	SK	Vnísky a predávajúci nenesú žiadnu zodpovednosť za nedodržanie príslušných ustanovení zákona, stavebných predpisov a bezpečnostných požadavkov užívateľom výrobku, architektom, montérom alebo majiteľom objektu.